

Sri – Om
VEDIC MATHEMATICS AWARENESS YEAR

E-Newsletter Issue no 54 dated 11-12-2014

For previous issues and further more information visit at www.vedicganita.org

'Credit goes to Swami Bharti Krshna Tirtha Ji Maharaj to focus the attention of present generation about the values of Ganita Sutras (mental Mathematics Sutras)'

All are invited to join Awareness program

All are warmly invited to join the awareness program of Vedic Mathematics. All teachers, parents and students are invited to Learn and Teach Vedic Mathematics for proper intelligence growth at School.

Dr. S. K. Kapoor
Sh. Rakesh Bhatia
Sh. Bhim Sein Khanna
Sh. Deepak Girdhar
- Organizers

ISSUE NO 54

	Page	
Chapter – 6		1-4
Emergence of Sky within space		

VMS & T Project
School Text Books
(Class IX, X, XI & XII)

=====

VMS & T Text Book Class XI
(5-space)

Chapter - 6
Emergence of Sky within space

1. The emergence of sky within space is of the format of solid order set up within hyper solid 4 set up.
2. Its chase initiation is to be from the origin of 4-space / center of hyper cube 4 / origin fold of hyper cube 4 / transcendental (5-space) origin seat at center of hyper cube 4 as it is of a solid dimensional order.
3. This emergence chase because of the solid order would be of three phases and stages parallel to three dimensional frame of solids / 3-space bodies.
4. Sequentially this chase may be expressed at its first stage as parallel to the split of a sphere as a pair of hemispheres coordinated by the vertical axes, permitting expression as under :-

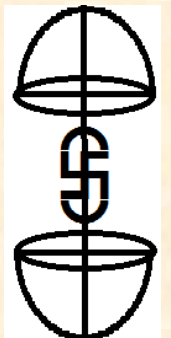

5. The second phase and stage shall be availing format of a pair of linear axis set up which may permit expression as under:-

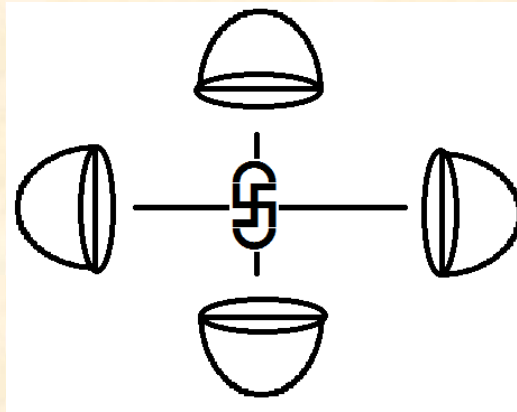

6. The final, third stage of expression shall be availing the format of full three dimensional frame and same would permit expression as under :-

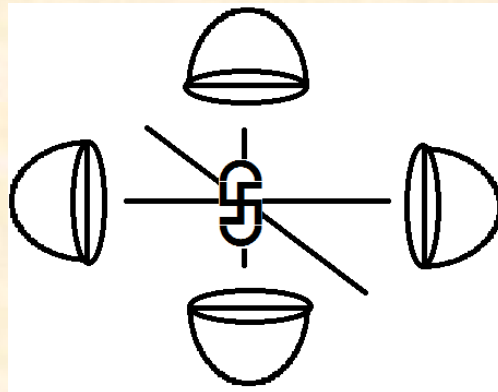

7. As the solid dimensional frame (3-space as dimension) of transcendental (5-space) domain shall be providing linear equivalence value $1 \times 3 \times 5 = 15$, as such the expression along the first axis set up would be of triple values (15, 16, 17) permitting expression as under

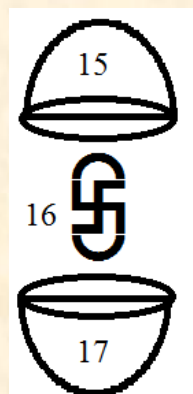

8. The second phase and stage of the format of pair of axes shall be having values formats (15, 16, 17) and (17, 18, 19).

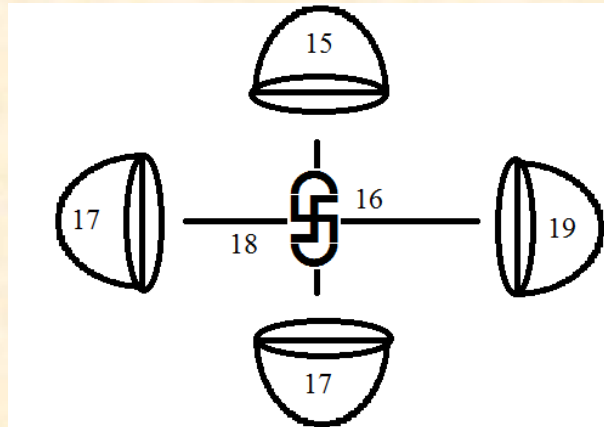

9. The final stage expression values triples would be (15, 16, 17), (17, 18, 19) and (19, 20, 21)

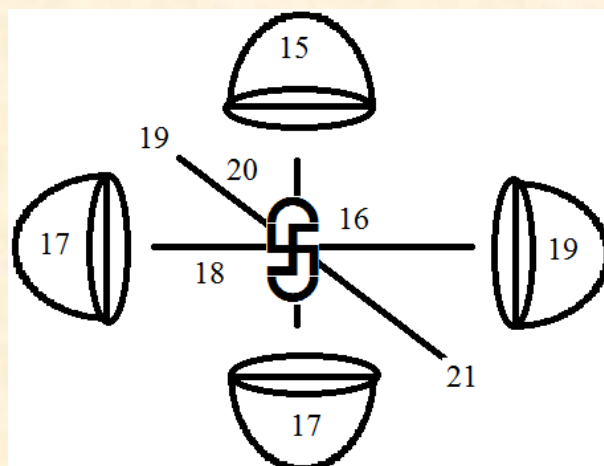

10. With it there would be a re-split in a manifested form within hyper cube 4 as hyper sphere into a pair of hyper spheres, as fourth phase and stage whereby there would be coordination for the eight solid boundary components of hyper cube 4 into four pairs of such components accepting triple values as (15, 16, 17), (17, 18, 19), (19, 20, 21) and (21, 22, 23)

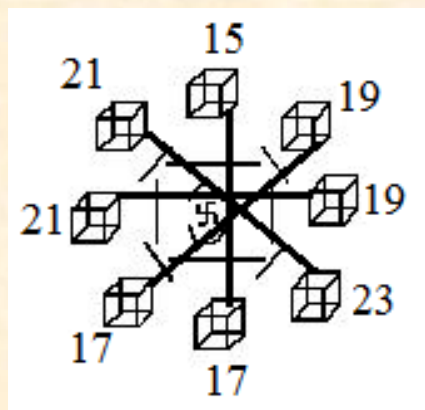

11. Finally the transcendental (5-space) stage reach would be of following values triples
 (15, 16, 17), (17, 18, 19), (19, 20, 21), (21, 22, 23), (23, 24, 25)

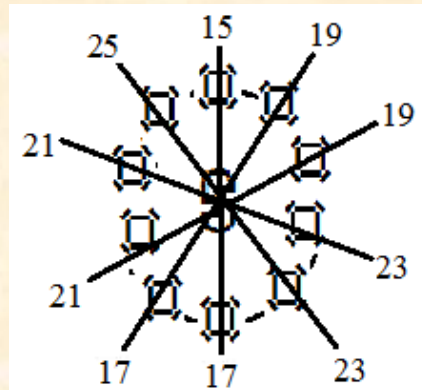

12. One may have a pause here and take note that ten directional frame is sustained by a solid order (3-space set up) which may permit expression as under:-

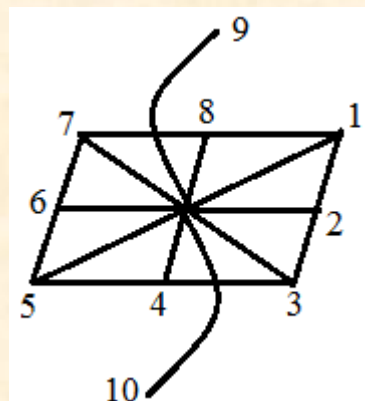

*

Note:- Exercises notes would follow after completion of the first outline of the text of sixteen chapters range of the Text Book of Class XI.

11-12-2014

Dr. S. K. Kapoor, *(Ved Ratan)*